

## New USPS prices take effect January 27, 2013.

### First-Class Mail®

The shape and format of your mailpiece continue to have a significant impact on your cost. You can save \$0.003 for each letter that complies with the full-service Intelligent Mail® requirements.

Select Rates for First-Class Mail®	2012	Jan '13
Single-piece Letter – First ounce	\$0.45	\$0.46
Single-piece Flat – First ounce	\$0.90	\$0.92
Single-piece Parcel – 1-3 oz.	\$1.95	\$2.07
Each additional ounce (letters and flats)	\$0.20	same
Each additional ounce (parcels)	\$0.17	same
Nonmachinable surcharge	\$0.20	same
Presorted Letter – First ounce	\$0.424	\$0.433
Presorted Flat – First ounce	\$0.762	\$0.772
Automation Letter – 5 digit – First ounce	\$0.350	\$0.360
Automation Flat – 5-digit – First ounce	\$0.400	\$0.406
Postcards	\$0.32	\$0.33

### Standard Mail®

Continue to earn discounts for automation and NDC/SCF Destination Entry. Save \$0.001 on letters that comply with full-service Intelligent Mail® requirements.

Select Rates for Standard Mail®	2012	Jan '13
Letter no more than 3.3 oz. – AADC (Nonautomation)	\$0.265	\$0.274
Flat no more than 3.3 oz. – ADC (Nonautomation)	\$0.528	\$0.542
Letter no more than 3.3 oz. – 5-digit (Automation)	\$0.242	\$0.247
Flat no more than 3.3 oz. – 5-digit (Automation)	\$0.353	\$0.362
NDC Destination Entry Discount (Piece Rate)	\$0.033	same
SCF Destination entry Discount (Piece Rate)	\$0.043	same

### Priority Mail®, Express Mail® and Package Services

Business mailers who send mail using Priority Mail® or Express Mail® service may be eligible for Commercial Pricing – discounts made easier with your Pitney Bowes digital mailing system.

Select Retail Rates for Priority Mail®, Express Mail® and Package Services	2012	Jan '13
Priority Mail® – Flat Rate Envelope	\$5.15	\$5.60
Priority Mail® – Small Flat Rate Box	\$5.35	\$5.80
Priority Mail® – Medium Flat Rate Box	\$11.35	\$12.35
Priority Mail® – Large Flat Rate Box	\$15.45	\$16.85
Express Mail® – Flat Rate Envelope	\$18.95	\$19.95
Standard Post – 1 lb. Single-Piece	\$5.20	\$5.60
Media Mail – 1 lb. Single-Piece	\$2.47	\$2.53
Library Mail – 1 lb. Single Piece	\$2.35	\$2.40

### Extra Services

The USPS offers many services that can help you confirm delivery. Take a moment to understand your choices so you can select the best option for your business.

Select Rates for Extra Services	2012	Jan '13
Registered Mail™ Base Rate	\$10.95	\$11.20
Certified Mail™	\$2.95	\$3.10
Return Receipt (paper based)	\$2.35	\$2.55
Electronic Return Receipt	\$1.15	\$1.25
First-Class Address Correction – Manual	\$0.50	\$0.55
First-Class Address Correction –Electronic	\$0.10	\$0.11

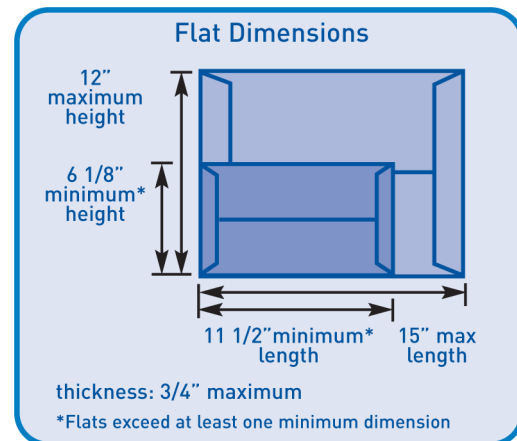
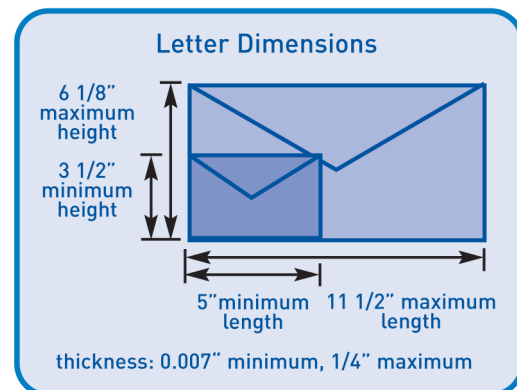
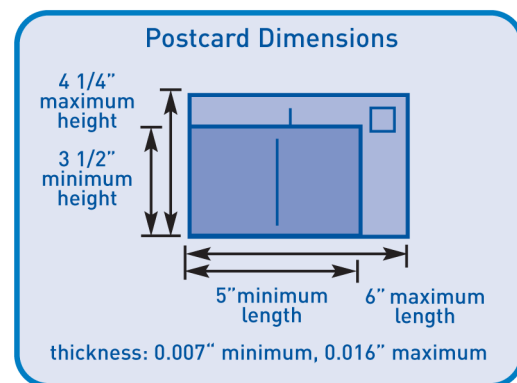

For more details, including new rate tables, please visit [www.usps.com/prices](http://www.usps.com/prices).